



US CMS EMU

ME234/2 chamber AFEB-ALCT cabling/integration

Prepared by N.Bondar

Updated 08/02/01

List of material

Position #	Assembly component	part number	Quantity
1	ME234/2 chamber with cooling pad		1
	Cable strain relief set:		
2	Bottom part	MC-400017	1
3	Top part	MC-400017	1
4	Screw M6 x18	BN610	6
5	AFEb/P	MC-400010	24
	AFEb bracket set:		24
6	AFEb bracket	MB-400055	24
7	Screw M4 x10 (thread forming)	BN	48
8	Flat washer		48
9	Lock (star) washer		48
10	AFEb cover stand-off	MB-400021	6
11	Screw M6 x25 (thread forming)	BN	12
	AFEb-ALCT cable set:		
12	4 Pitch LH	MC-400075	3
13	4 Pitch RH	MC-400076	3
14	6 Pitch LH	MC-400078	3
15	6 Pitch RH	MC-400079	3
16	9 Pitch LH	MC-400080	3
17	9 Pitch RH	MC-400081	3
18	11 Pitch LH	MC-400082	3
19	11 Pitch RH	MC-400083	3
20	Cable tie	PLT4S-M 14-1/2	25
21	Cable strain relief part	RBPR-110	24
22	Screw M5 x25 (thread forming)	BN	12
23	Harness bracket	MB400065	1
24	Screw M5 x8		2
25	Adhesive cable tie mounts	ABNS-A-C	8
	Tooling:		
	Torque wrench		1
	Power screwdriver		1
	Screwdriver Philips		1
	Screwdriver flat		1
	Screwdriver socket 7 mm		1
	Screwdriver socket 8 mm		1
	Screwdriver socket 10 mm		1
	Hex screwdriver 5 mm		1
	Wire cutter		1
	Rig:		
26	Cable clamp holder		16
	Other material:		
	Alcohol		10g

Before the cable installation:

- Install the cooling pad on the chamber , TD#5520-ME-400056....
- Install ALCT board on the cooling pad,
- Install the anode amplifier boards (AFEB) pos.5, MC-400010 *
- Install the anode cover standoffs pos.10, TD# MB-400021*

Install the cable strain relief clamp pos. 2, using two M6 screws pos.4.

See Fig.1 for reference.

*) – It is not necessary to install these parts for harness assembly.

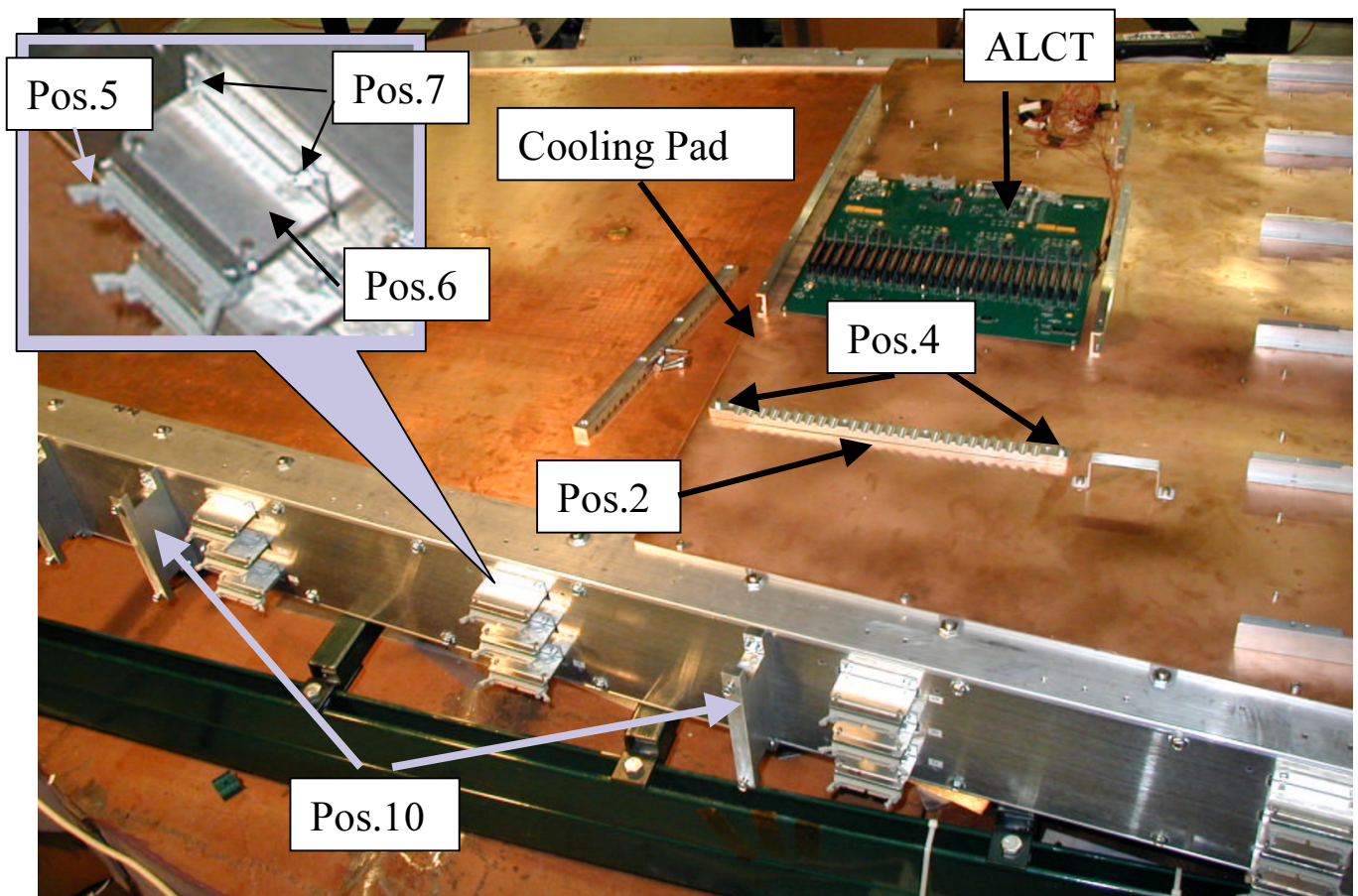

Fig.1. ME234/2 chamber prepared for cable harnessing and cable installation

Cable harness assembling.

- Connect AFEB-ALCT cables to the ALCT board. The cable number must match the ALCT input connector number. Start connecting from the largest cable number.

Note: The cable drawing number label is located on the ALCT side of the cable!

- Spread the cables along the strain relief bar in the corresponding slots.
- Install the top part of the strain relief –3 with M6 screws –4. Tighten the cables firmly but gently. Avoid cable pinching.

See Fig.2 for reference.

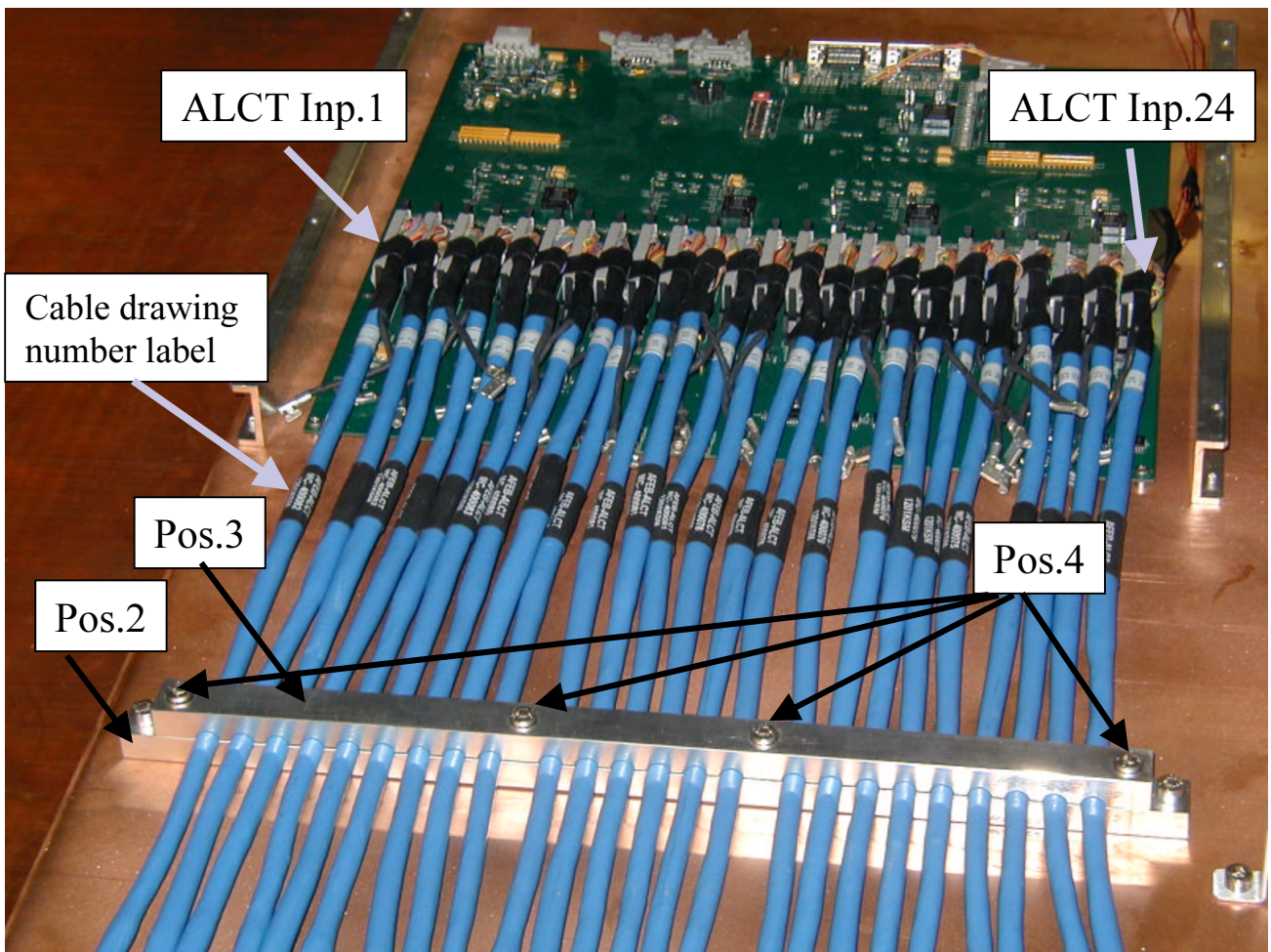

Fig.2. Cables clamped near the ALCT input

- Stretch cables number 1, 2 and 3 along the chamber, with cable number 1 on the bottom, then cable number 2, and finally cable number 3 on the top. Fix the three cables together temporarily into a bundle using the metal cable clamp holders.
- Stretch the next three cables 4, 5, 6 in the same order, using the same technique.
- Stretch the next three cables 7, 8, 9 in the same order, using the same technique.
- Stretch the next three cables 10, 11, 12 in the same order, using the same technique.
- Stretch the next three cables 13, 14, 15 in the same order, using the same technique.
- Stretch the next three cables 16, 17, 18 in the same order, using the same technique.

See Fig.3, Fig.3a for reference.

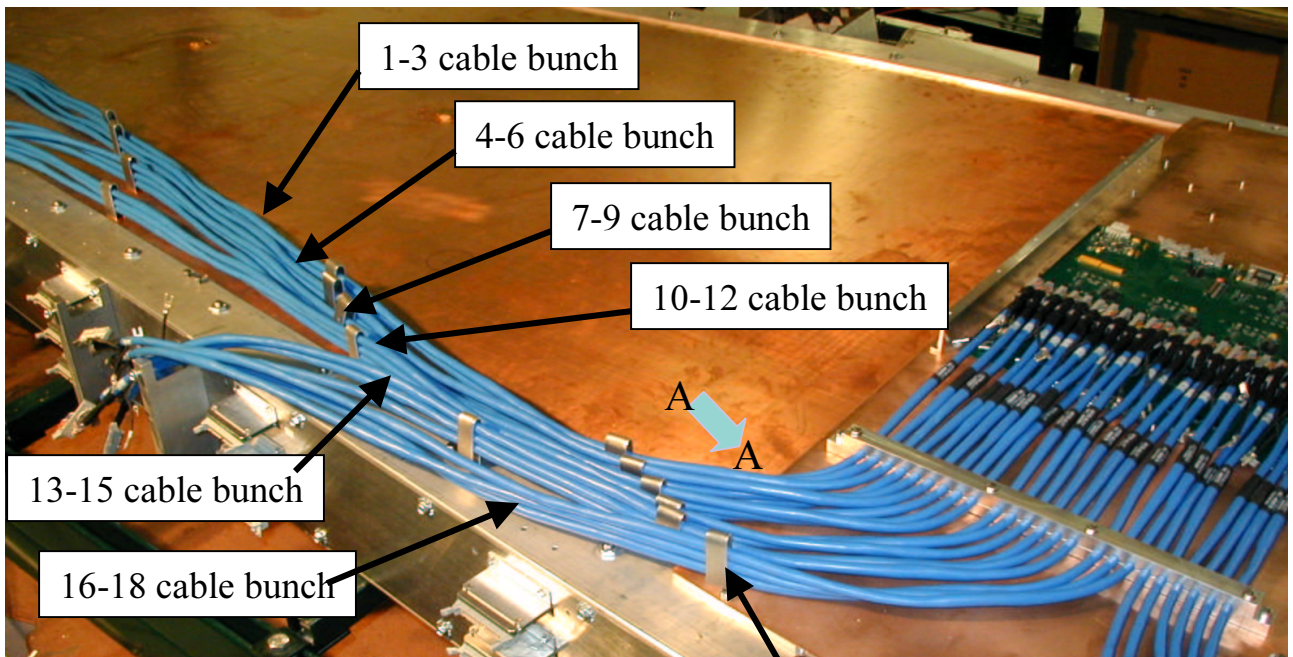
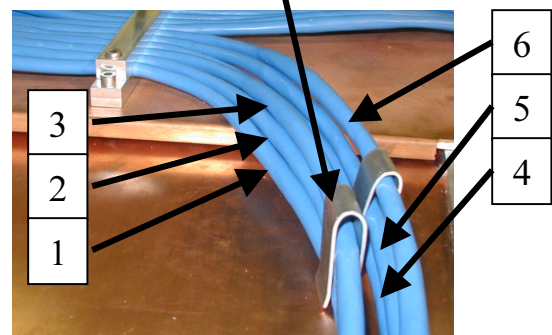

Fig.3. Pre-aligned cables on the top of the chamber

Fig.3a. The vertical cables order.
A-A direction view .

Cable clamp holder, pos. 25



- Equalize the curvature of cables 13, 14, 15, 16, 17, 18 and tighten them into one bundle using two cable ties PLT4S-M 14-1/2". Remove the metal cable clamps during the tightening. Put one cable tie near the edge of the cooling pad, and the second one about 4" further away. This is the bundle number 3.
- Equalize the curvature of cables 7, 8, 9, 10, 11, 12 and tighten them into one bundle using three cable ties PLT4S-M 14-1/2". Remove the metal cable clamps during the tightening. Put one tie near the edge of the cooling pad and spread others along the bundle. This is a bundle number 2.
- Equalize the curvature of cables 1, 2, 3, 4, 5, 6 and tighten them into one bundle using four cable ties PLT4S-M 14-1/2". Remove the metal cable clamps during the tightening. Put one tie near the cooling pad edge and spread others along the bundle. This is bundle number 1.

Use picture Fig.4 and Fig.4a for reference.

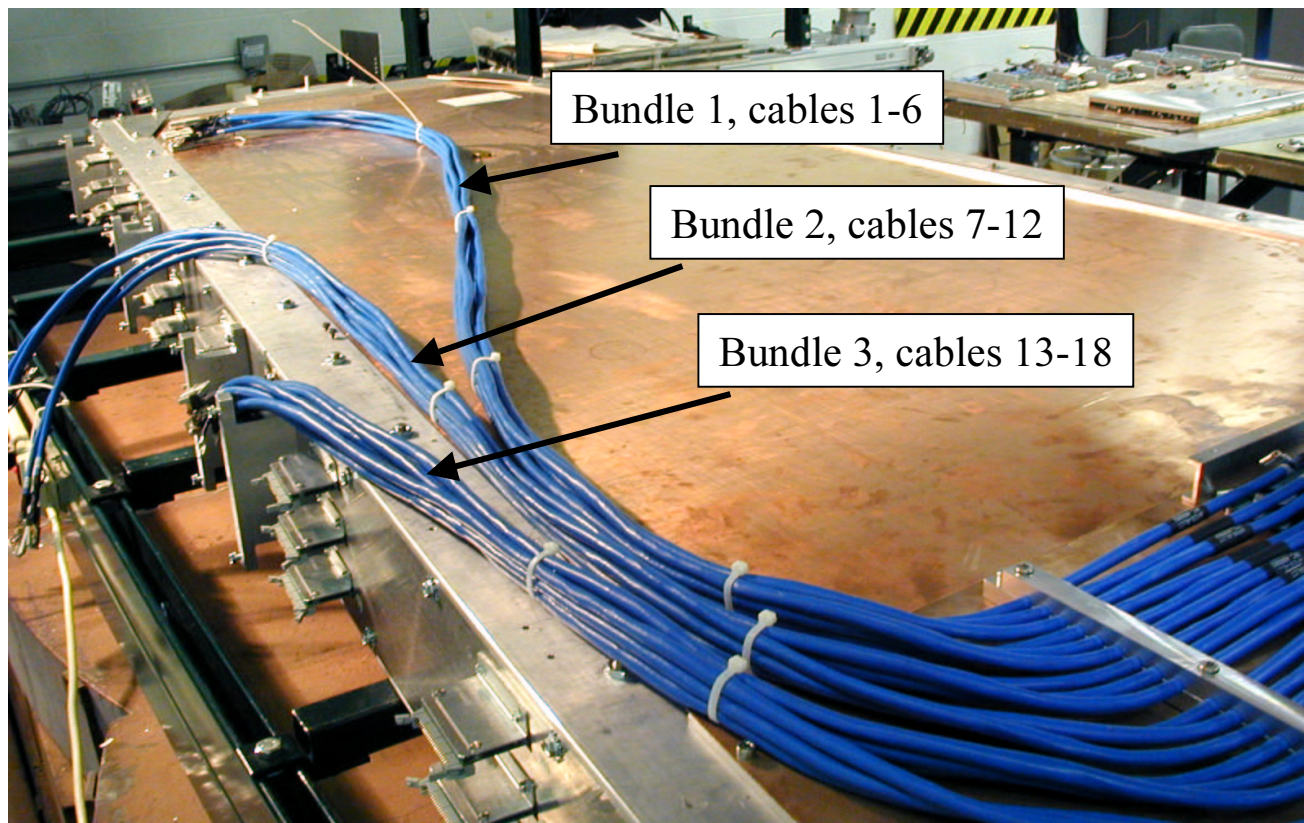
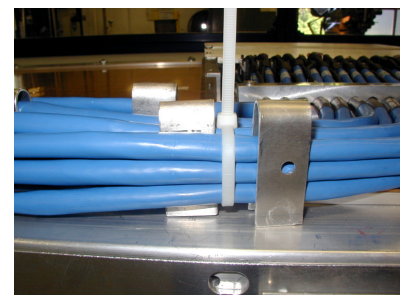

Fig.4. The initial bundles 1, 2 and 3 of long cables.

Fig.4a. The best way to tighten the cables is to do it between two clamps



- Equalize curvature of bundles 3 and 2 and tighten them together in one bundle using cable tie PLT4S-M 14-1/2" - 1
- Equalize curvature of bundle 2 and 1 and tight them together in one bundle using five cable ties PLT4S-M 14-1/2" - 2

The ME234/2 cable harness is ready .

If this harness is intended to be stored :

- unplug connectors from ALCT board
- disconnect the cable strain relief from the cooling pad by removing two M6 screws – 3
- Take off the harness from the chamber with the strain relief as one unit.

See Fig.5 for reference.

Note: Two persons must handle the harness

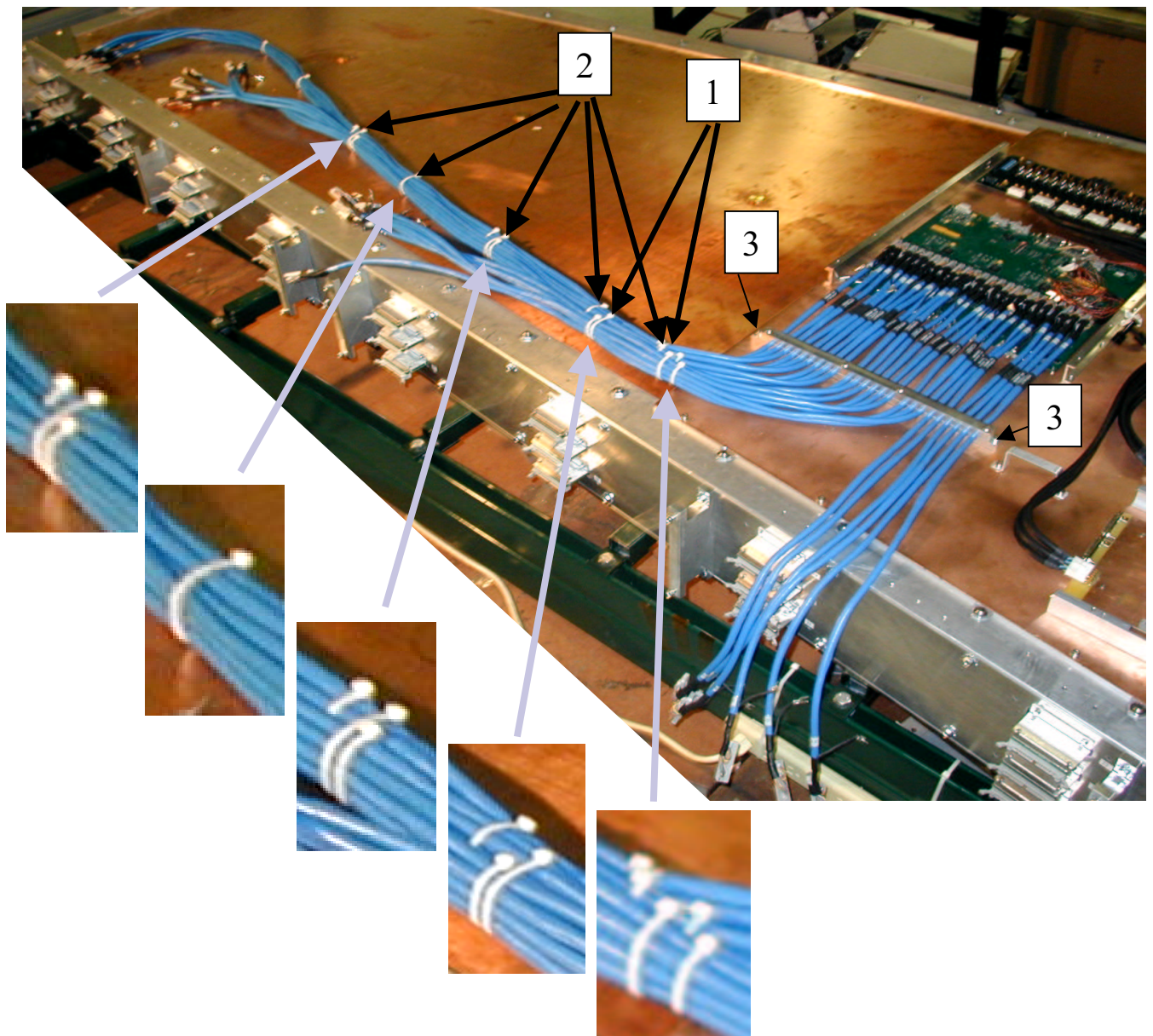

Fig.5. ME234 AEB-ALCT cable harness

The cable harness installation on ME234/2 chamber

- Prepare ME234/2 chamber for harness installation. Follow instructions on the slide 2.
- Take a harness from a shipping box and put the harness on the top of the chamber. Spread the harness on the chamber as shown on picture Fig.6

Note: Two persons must handle the harness.

- Attach the cable strain relief -1 to the cooling pad with two M6 screws pos.4.
- Plug in all connectors to the ALCT inputs (better start from the biggest cable number)

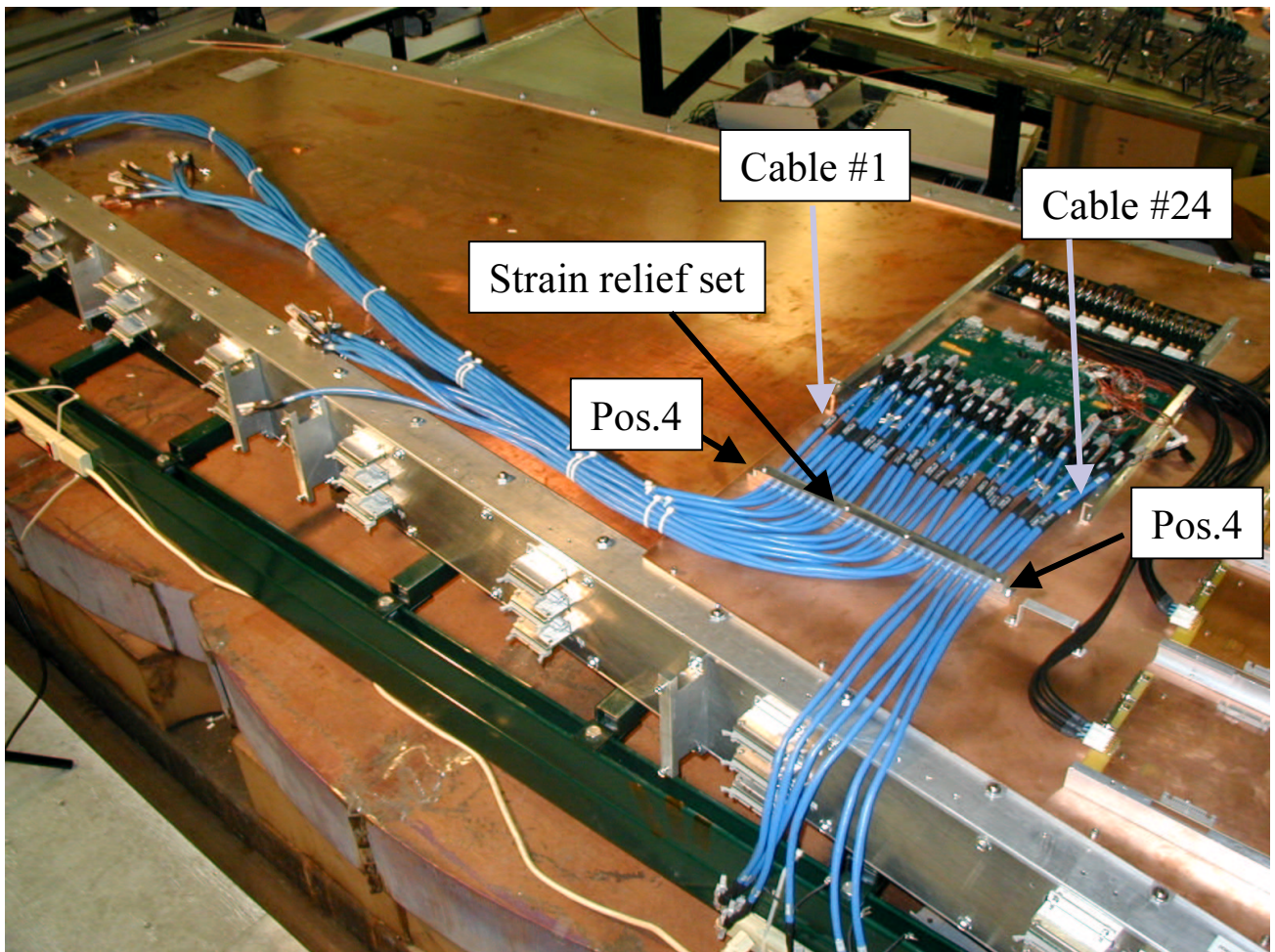

Fig.6. ME234/2 cable harness on the chamber

- Fix cables 19, 20, 21, 22, 23, 24 on the chamber frame with the cable strain relief RBPR –110 (pos.21) using screw M5 (pos. 22).
- Arrange all cables in the natural order. See Fig.4 for reference

RBPR –110 cable strain relief installation.

"The RBPR-110 strain relief consists of two identical plastic parts between which two cables are clamped. To clamp the cable into the strain relief, use a M5 x 25 thread-forming screw and a 8 mm socket screwdriver. There are unthreaded holes in the chamber frame with fit the strain relief screw. The first time you screw in the M5 screw, use alcohol as a lubricant. The maximum allowed torque to use on the screws is 24 inch-pounds. Notice that for the bundles of 3 cables, one of the slots in the strain relief is not used.

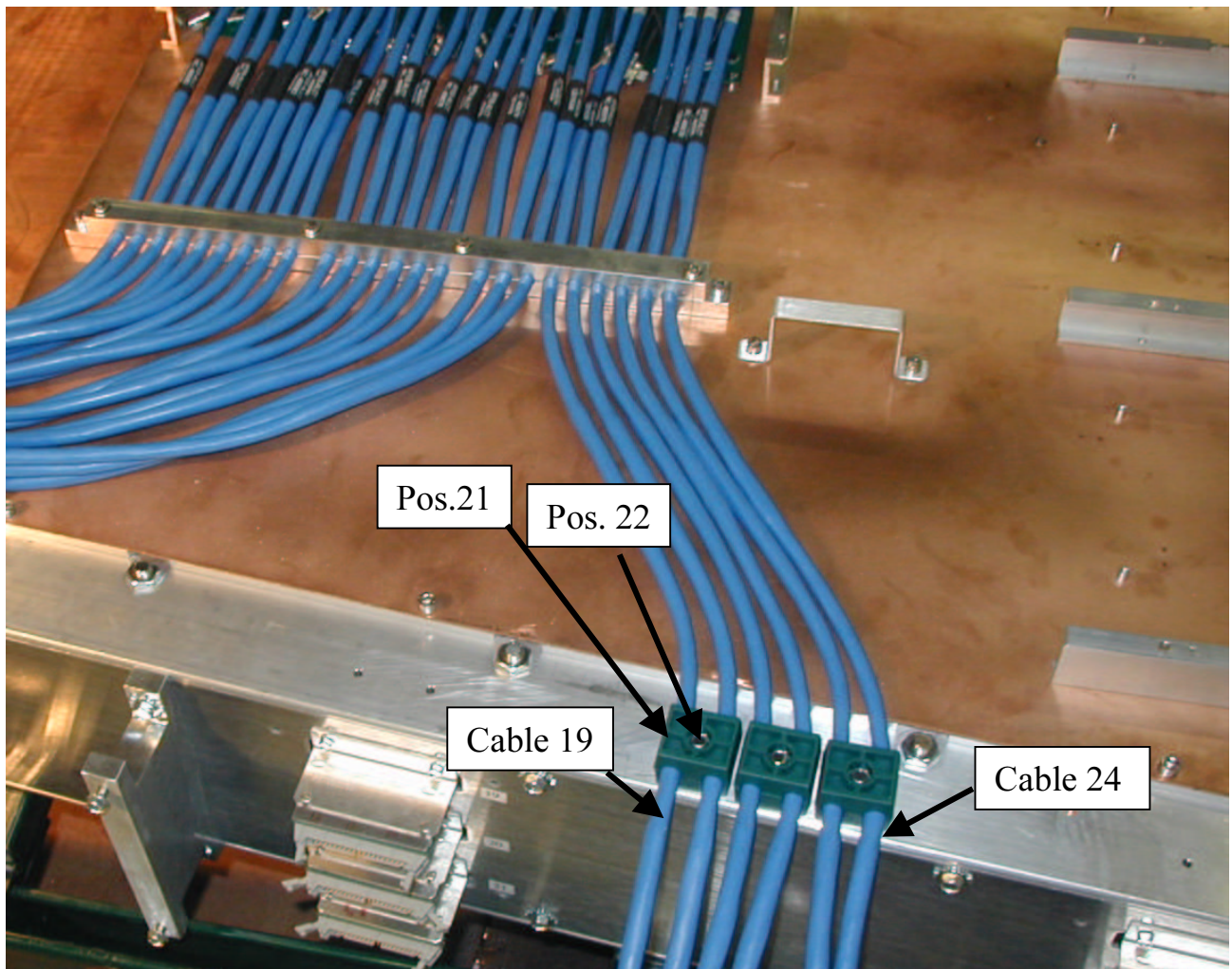

Fig.7. Cables 19 - 24 fixed on the chamber frame.

- Stretch the cables 13 - 18 out along the chamber, and fix them into the strain relief RBPR-110 in the following order from left to right: 15,14,13,16,17, and 18
 - Repeat the same procedure with cables 7-12 and fix the cables on the chamber frame in the following order from left to right: 9, 8, 7, 10, 11, and 12.
 - Repeat the same procedure with cables 1-6 and fix the cables on the chamber frame in the following order from left to right: 3, 2, 1, 4, 5, and 6.
 - Fix the harness with special bracket, see Fig. 8.
- See Fig.8, Fig.8a, Fig.8b, and Fig.8c for reference.

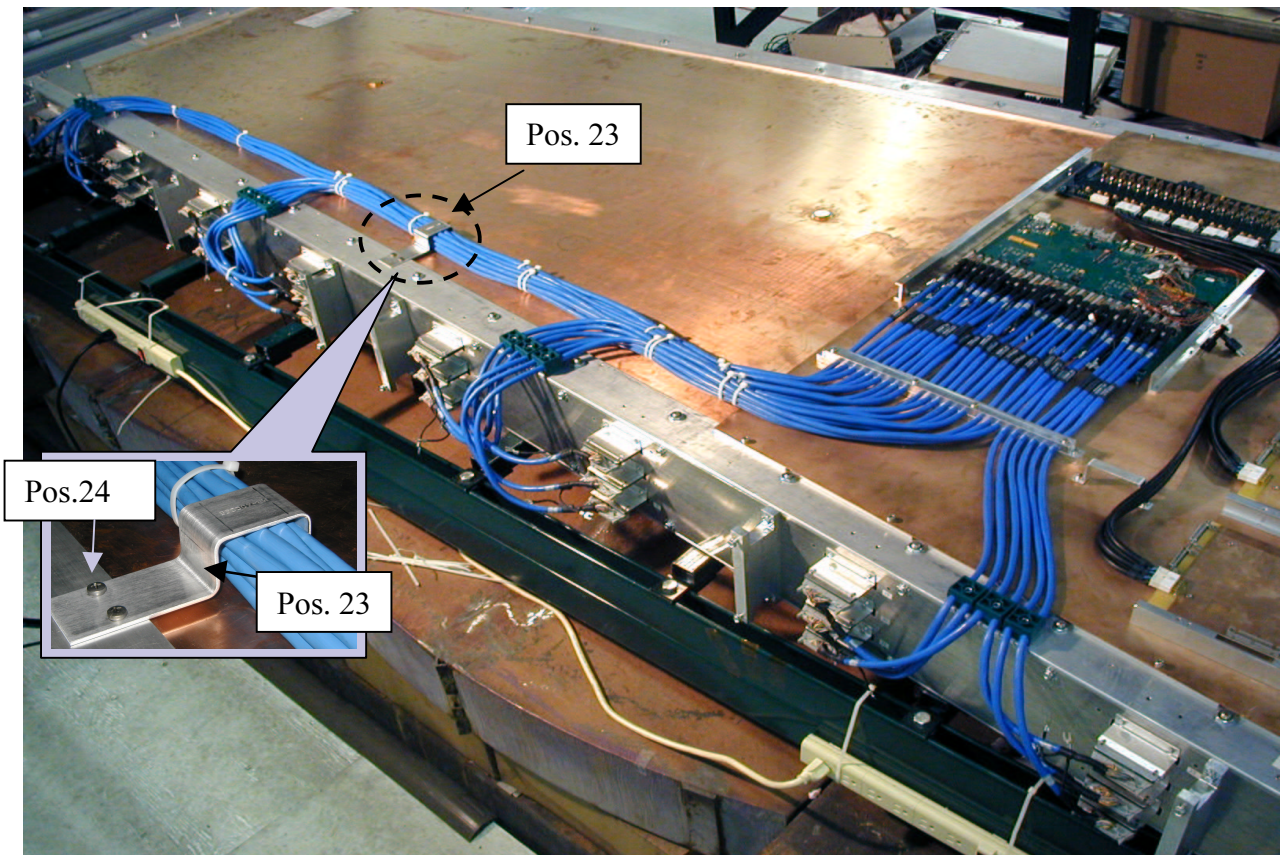

Fig.8. ME234/2 cable harness assembled on the ME234/2 chamber

-Connect each cable to the AFEb output. Match the label numbers on the cable to the numbers shown on the chamber side cover (AFEb position number).

All cables must go in a natural way, avoid a folded cable. Use pictures Fig.8a - Fig.8c for reference.

The cable ground wire terminal (cable shield) must be connected to the chamber ground. Use one of the M4 screws on the bracket (Fig.8).

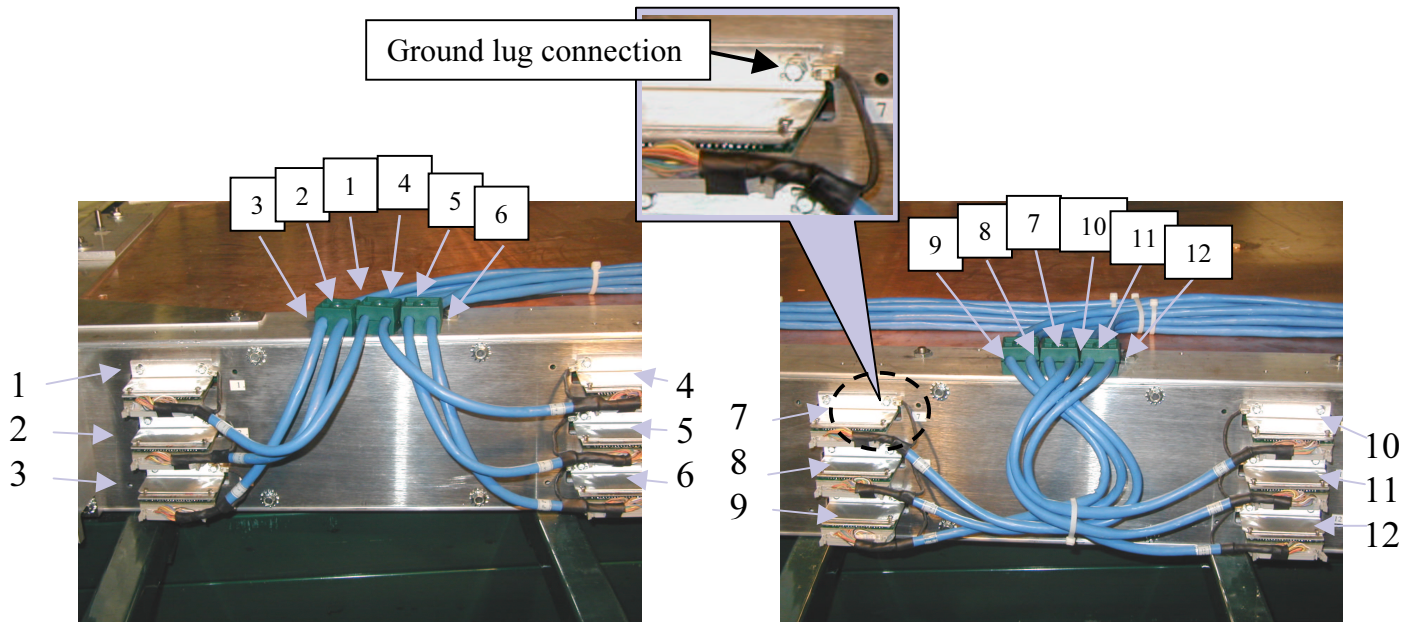

Fig.8a Cable layout and order for AFEB/s #1- #6

Fig.8b. Cable layout and order for AFEB/s #7 - #12

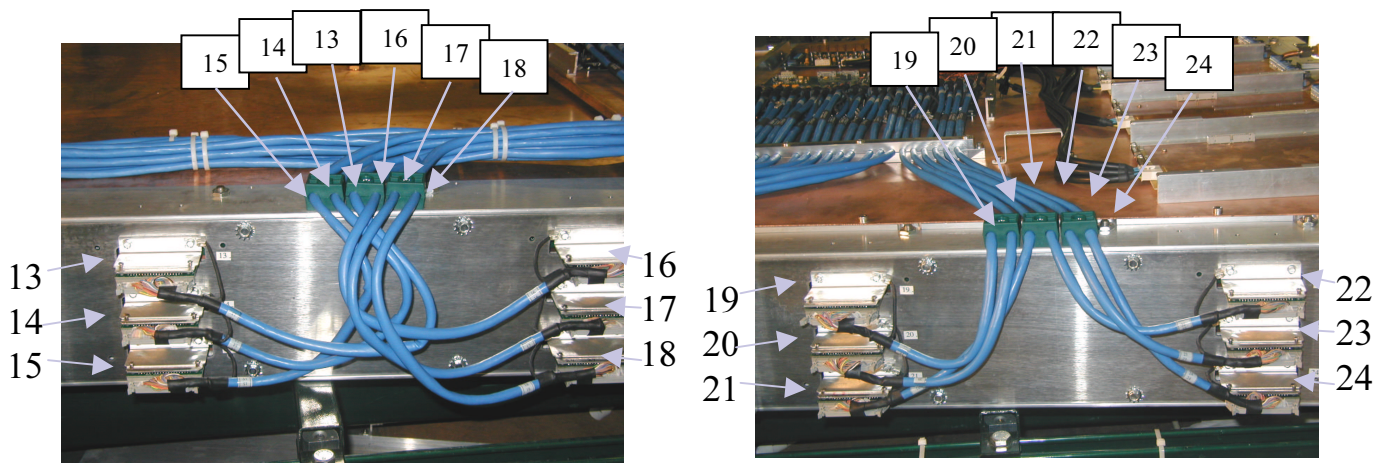

Fig.8c Cable layout and order for AFEB/s #13 - #18

Fig.8d Cable layout and order for AFEB/s #19- #24

These cables are in natural order.

Fix cables on the chamber side cover with cable ties using adhesive cable tie mounts. Align cables at the AFEB connector sides according pictures at Fig.9a, 9b, 9c, 9d. **Cable must be aside of the AFEB connector latch.**

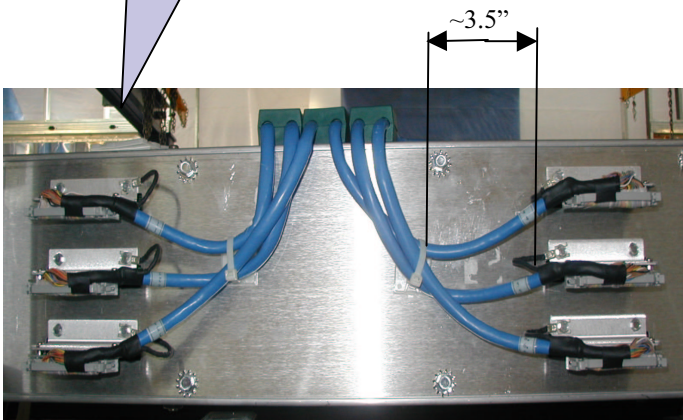
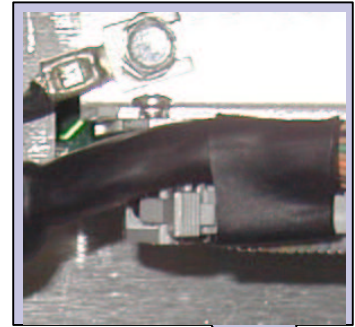
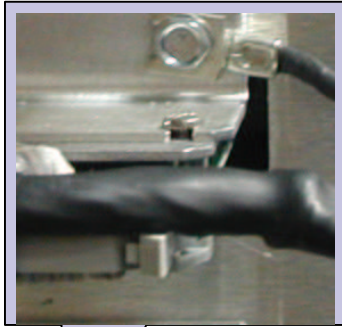

Fig.9a Cable layout for AFEB/s #1- #6

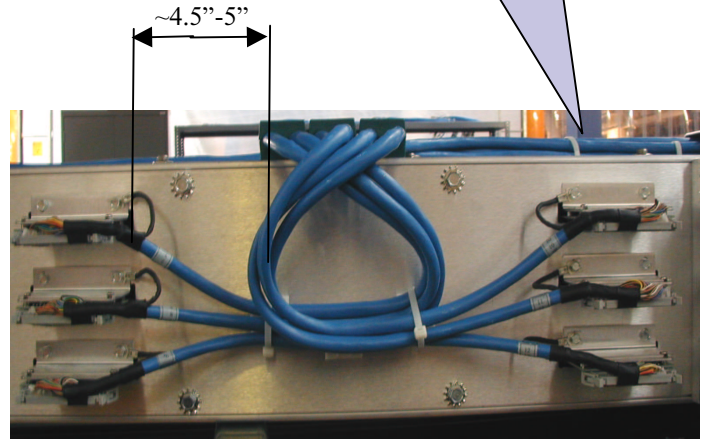

Fig.9b. Cable layout for AFEB/s #7 - #12

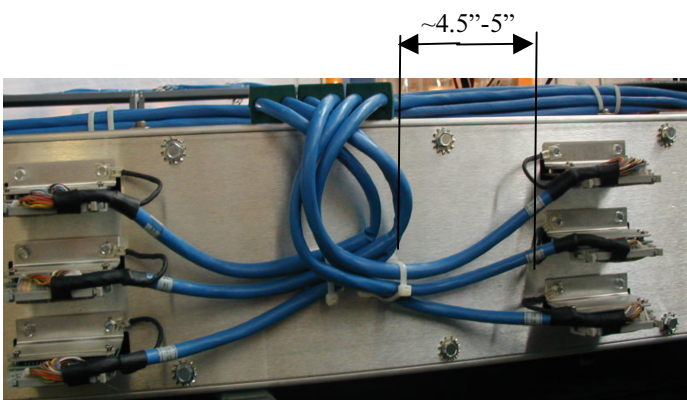

Fig.9c Cable layout for AFEB/s #13 - #18

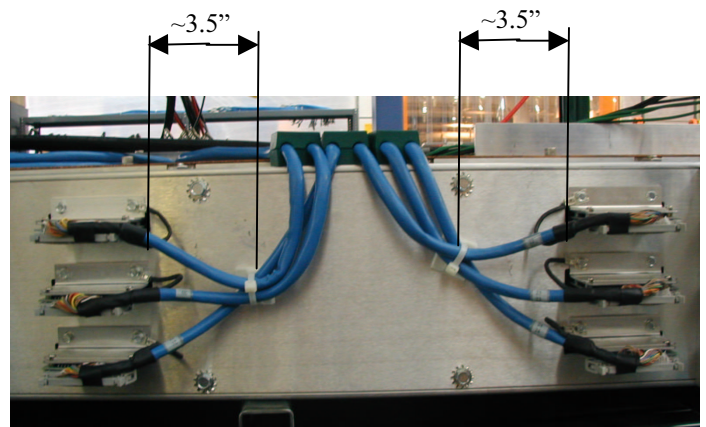

Fig.9d Cable layout for AFEB/s #19 - #24